

序号	名称	材料
1	插针	黄铜 (镀锡)
2	基座	LCP(U194-0)
3	焊片	磷青铜 (镀锡)

- A
- Current rating: 1A AC/DC (AWG #26)
 - Voltage rating: 50V AC/DC
 - Temperature range: -25°C to 85°C
 - Contact resistance: Initial value/20m Ω max
Electrical properties
 - Insulation resistance: 100M Ω min
 - Withstanding voltage: 500V AC/ minute
 - Applicable wire: AWG #30 to #26
- Environmental controls
- Banned contains SS - 00259 are restricted substances.
 - The corresponding issued by SGS or ITS Top-ases data, Not the material in a list, and validity.

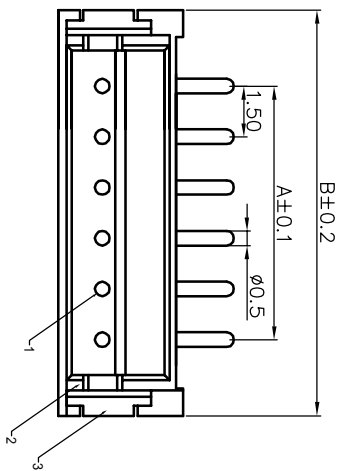

孔位 poles	A	B
2	1.50	6.00
3	3.00	7.50
4	4.50	9.00
5	6.00	10.50
6	7.50	12.00
7	9.00	13.50
8	10.50	15.00
9	12.00	16.50
10	13.50	18.00
11	15.00	19.50
12	16.50	21.0

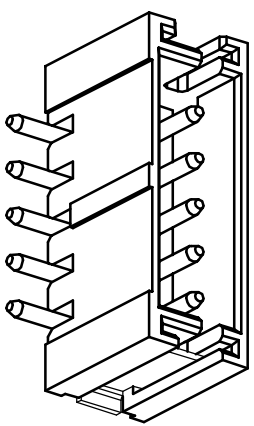
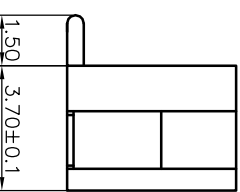
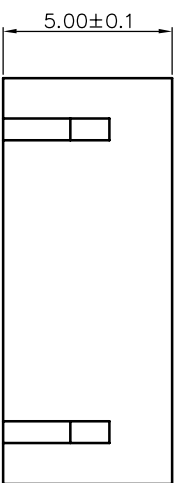
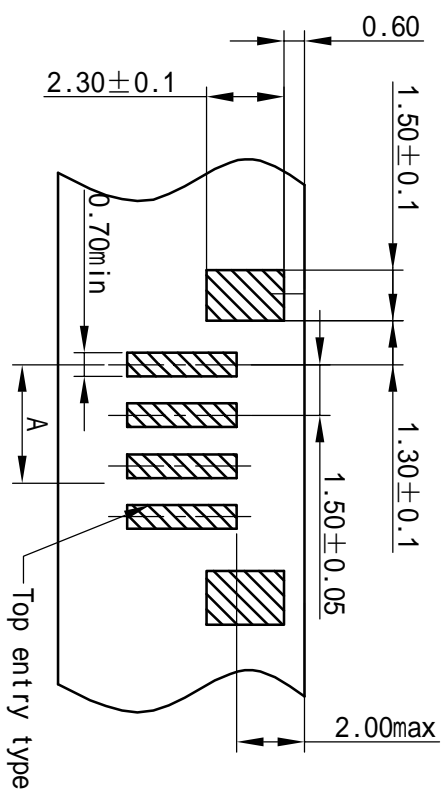

深圳市文章济美科技有限公司

尺寸公差	角度公差	品名:	设计
.X ±0.1	.X° ±0.1°	ZH-nAB	JINWENJING
.XX ±0.05	.XX° ±0.05°	图号:	审核
.XXX ±0.005	.XXX° ±0.005°	比例: --	JINWENJING
单位: mm	页数: 1/1	版本: A	批准

版次	日期	内容
A1	08-05-01	

产 品 规 格 书

PRODUCT SPECIFICATION

【1】适用范围 SCOPE

本规格书适用于：1.5mmZH 间距接压式条形连接器

This specification covers the 1.5mm Pitch SH Connectors serie.

【2】产品名称及型号 PRODUCT NAME AND PART NUMBER

产品名称 Product Name	产品型号 Part Number
1.5mmZH 条形接连器	

【3】定格 RATINGS

项目 Item	规 格	Requirement
最大容许电压 Rated Voltage(MAX)	500V	[AC(有效值 rms)/DC]
最大容许电流 Rated Current(MAX)	1A	
使用温度范围 Ambient temperature Range		-25℃ ~ +85℃

【4】性能 PERFORMANCE

4.1 电气性能 Electrical Performance

项目 Item		条 件 Test Condition	规格 Requirement
4.1.1	接触电阻 Contact Resistance	开放电压 20mV 以下；短路电流 10mA 的状态下测定。 measure by dry circuit, 20mV MAX, 10mA.	0.01mΩ MAX
4.1.2	绝缘电阻 Insulation Resistance	相邻端子间或端子与地面间加 DC 100V 下测定。 apply 100V DC between adjacent terminal or ground.	100MΩ MIN
4.1.3	耐电压 Dielectric	相邻端子间或端子与地面间加 AC 500V（有效值）历时 1 分钟下测定。 apply 500V AC (min) for 1minute between adjacent terminal or ground.	无击穿现象 No Breakdown

4.2 机械性能 Mechanical Performance

项目 Item		条 件 Test Condition	规格 Requirement
4.2.1	锁紧力及拔出力 Locking and Withdrawal Force	用每分钟 25±3mm 的速度；平行地插入、锁紧、拔出。 the speed rate of 25±3mm/minute.	锁紧力 Locking 1.96*n (N) MAX 拔出力 Withdrawal 0.49*n (N) MIN
4.2.2	端子保持力 Terminal /Housing Retention Force	以用每分钟 25±3mm 的速度平行向外拉 Pull the terminal at the speed rate of 25±3mm per minute	3.92 N MIN

4.3 环境和其他性能 Environmental Performance and Others

项目 Item		条 件 Test Condition	规格 Requirement	
4.3.1	重复插拔 Repeated Insertion and Withdrawal	无通电状态；以 10 次/分钟的速度插拔 20 次 Insertion and withdrawal catuator up to 20 cycles at the speed rate of less than 10 cyclea/minute	接触抵抗 Contact Resistance	60 mΩ MAX
4.3.2	温度上升 Temperature Rise	最大容许电流通电，温度测定。（UL 498） Carrying rated current load. (UL 498)	温度上升 Temperature Rise	30°C MAX

项目 Item		条件 Test Condition	规格 Requirement	
4.3.3	耐振动性 Vibration	DC 1mA 通电状态下; 嵌合轴沿 XYZ 三个方向振动; 振幅 1.5mm; 频率 10-55-10Hz/分; 历时 2 小时 Amplitude: 1.5mm P-P Sweep time: 10-55-10Hz in 1 minute Duration: 2 hours in each X.Y.Z. axes	外观 Appearance	无损坏 No Damage
			接触抵抗 Contact Resistance	60 mΩ MAX
			瞬断 Discontinuity	1 ms.MAX.
4.3.4	耐冲击性 Shock	DC 1mA 通电状态下; 嵌合轴沿相互垂直的 6 个方向; 以 490m/s ² {50G}冲击; 各 3 次 490m/s ² {50G}, 3 strokes in each X.Y.Z. axes.	外观 Appearance	无损坏 No Damage
			瞬断 Discontinuity	1 ms.MAX.
4.3.5	耐热性 Heat Resistance	85±2℃的空气中; 放置 96 小时; 再回到室温中放置 1-2 小时 85±2℃, 96 hour	外观 Appearance	无损坏 No Damage
			接触抵抗 Contact Resistance	60 mΩ MAX
4.3.6	耐寒性 Cold Resistance	-40±2℃的空气中; 放置 96 小时; 再回到室温中放置 1-2 小时 -40±2℃, 96 hour	外观 Appearance	无损坏 No Damage
			接触抵抗 Contact Resistance	60 mΩ MAX
4.3.7	耐湿性 Humidity	40±2℃、相对湿度 90-93%的空气中; 放置 96 小时; 再回到室温中 0.5 小时内测定 Temperature: 40±2℃ Relative Humidity: 90-93% Duration: 96 Hours	外观 Appearance	无损坏 No Damage
			接触抵抗 Contact Resistance	60 mΩ MAX
			耐电压 Dielectric Strength	必须满足 4.1.3 Must meet 4.1.3
			绝缘抵抗 Insulation Resistance	20 MΩ MIN
4.3.8	温度循环 Temperature Cycling	-25±3℃ 30 分钟; 常温常湿 10-15 分钟; 85±2℃ 30 分钟; 常温常湿 10-15 分钟, 循环 5 次。 5 cycles of: a) -25±3℃ 30 minutes b) 85±2℃ 30 minutes	外观 Appearance	无损坏 No Damage
			接触抵抗 Contact Resistance	60 mΩ MAX

项目 Item		条件 Test Condition	规格 Requirement	
4.3.9	耐盐雾性 Salt Spray	35±2℃、5±1%的盐水喷雾 48 小时； 试验后常温水洗；再室温干燥。 48±4 hours exposure to a salt spray from the 5±1% solution at 35±2℃ .	外观 Appearance	无损坏、腐蚀 No Damage
			接触抵抗 Contact Resistance	60 mΩ MAX
4.3.10	耐亚硫酸 SO2 Gas	40±2℃、50±5ppm 的亚硫酸中放置 24 小时 24 hours exposure to 50±5ppm. SO2 gas at 40±2℃ .	接触抵抗 Contact Resistance	60 mΩ MAX
4.3.11	耐氨性 NH3 Gas	浓度为 28%的氨水容器中；放置 40 分 钟。 40 minutes exposure to NH3 gas evaporating from 28% Ammonia solution	外观 Appearance	无损坏 No Damage
			接触抵抗 Contact Resistance	60 mΩ MAX
4.3.12	可焊性 Solderability	端子前端基准面 0.2mm 处浸入 235± 5℃的锡槽中；历时 2±0.5 sec。 Soldering Time: 2±0.5 sec. Soldering Temperature: 235±5℃ 0.2 mm from terminal tip	沾敷性 Solder Wetting	沾敷面积 95%以上
4.3.13	耐焊接热 Resistance to Soldering heat	端子前端基准面 0.2mm 处浸入 260± 5℃的锡槽中；历时 5±0.5 sec。 Soldering Time: 5±0.5 sec. Soldering Temperature: 260±5℃ 0.2 mm from terminal tip	外观 Appearance	无损坏、变形 No Damage

() : 参考规格 Reference Standard

{ } : 参考单位 Reference Unit

【5】外观形状、寸法及材质 PRODUCT SHAPE, DIMENSIONS AND MATERIALS

图面参照 Refer to the drawing.

名称 NAME	材质 MATERIALS
基座 Housing	LCP(本色) UL 94V-0
插簧 Contact	铜 Phosphor Bronze
备注 Remark	金属表面镀锡