

1 2 3 4 5 6 7 8

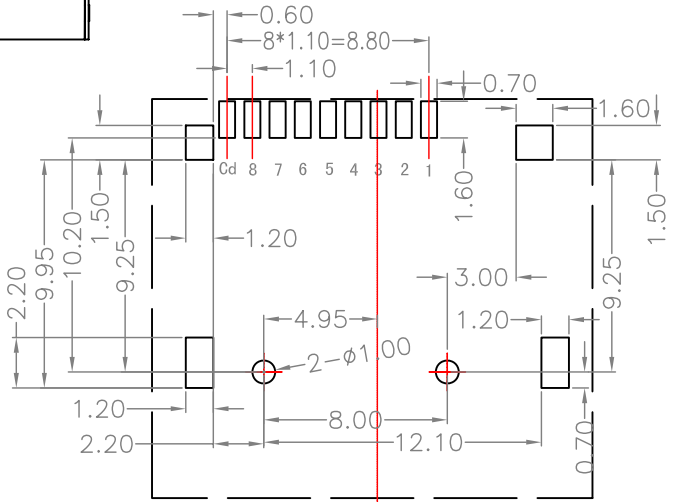
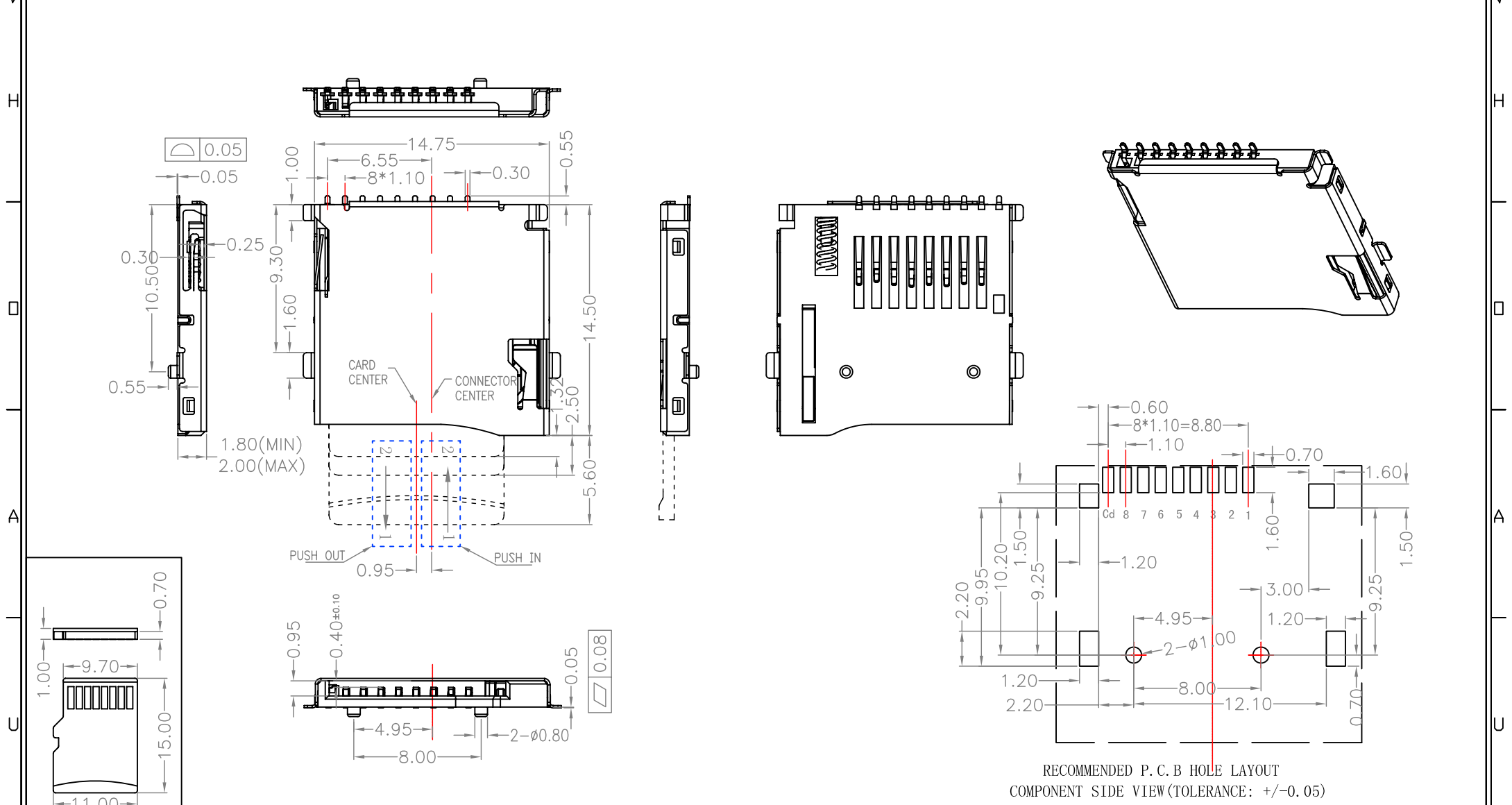

RECOMMENDED P. C. B HOLE LAYOUT
COMPONENT SIDE VIEW (TOLERANCE: +/-0.05)

NOTES:

- 1. MATERIAL:
HOUSING: HIGH TEMPERATURE THERMOPLASTIC
UL94V_0, COLOR:BLACK.
CONTACT: COPPER ALLOYS.
COVER: COPPER ALLOYS OR STEEL.
- 2. PLATING:
UNDERPLATE: NICKEL.
CONTACT AREA: GOLD OVER NICKEL.
SOLDER AREA: TIN OVER NICKEL.
- 3. MULTIMEDIA CARD COMPATIBLE

PIN NO.	NAME	YYPE	DESCRIPTION
1	DAT2	I/O/PP	DATE LINE(BIT2)
2	CD/DAT3	I/O/PP	CARD DETECT DATE LIN(BIT3)
3	CMD	PP	COMMAND RESPONSE
4	VDD	S	SUPPLY VOLTAGE
5	CLX	I	CLOCK
6	VSS	S	SUPPLY VOLTAGE GROUND
7	DATO	I/O/PP	DATE LINE(BITO)
8	DAT1	I/O/PP	DATE LINE(DIT1)

深圳市文章济美科技有限公司

TOLERANCE: X.X ±0.30 X.XX ±0.25 X.XXX ±0.15 X' ±2' X.X' ±0.5'	DRAWN BY : 吴迪	DATE : 2009-10-11	PART NAME: TF PUSH 外焊	
	CHECKED BY: 马跃	DATE : 2009-10-11	PART NO.	
UNIT: mm [inch] SCALE:1:1 SIZE: A4	APPROVED BY: 邱国夷	DATE : 2009-10-11	DRAW NO:	
			SHEET NO.	1 OF 3

8 7 6 5 4 3 2 1

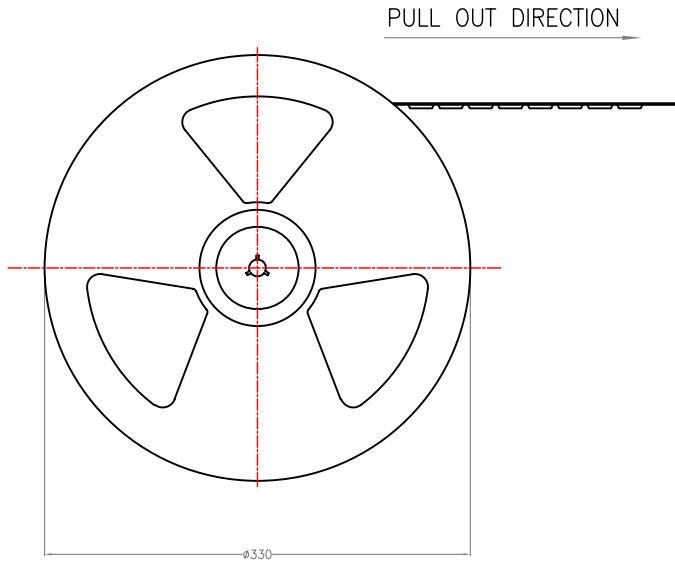
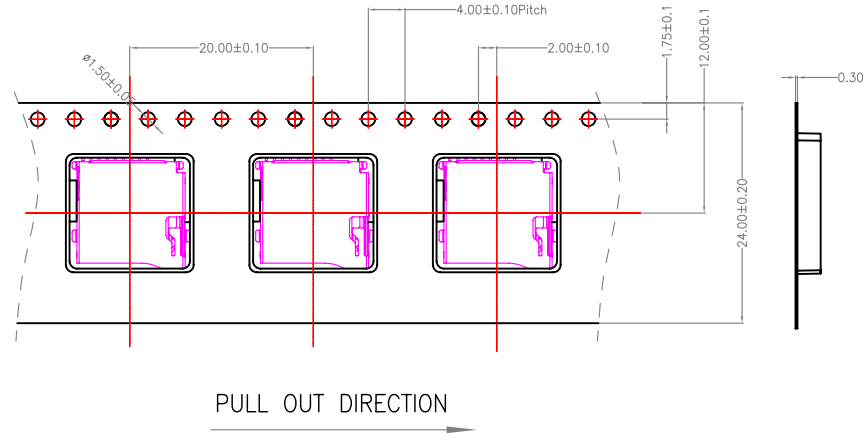
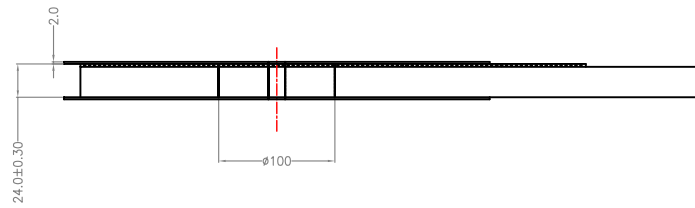

Note:

1. 10 sprocket hole pitch cumulative tolerance ± 0.2
2. Carrier camber is within 1 mm in 250mm.
3. Material: Black Conductive Polystyrene Alloy
100 % recyclable.
4. All dimensions meet EIA-481-B requirements.
5. Thickness: 0.3 ± 0.05 mm.
6. Component load per 13" reel: 1000 pcs.
7. A box of 10 volumes, 5000PCS
8. product weight: 6.5g; weight of a roll: 980g ; weight of a box: 5100g.
9. empty box: 200g / 45*345*155

深圳市文章济美科技有限公司

TOLERANCE: X.X ± 0.30 X.XX ± 0.25 X.XXX ± 0.15 X.' $\pm 2'$ X.X' $\pm 0.5'$	DRAWN BY : 吴迪	DATE : 2009-10-11	PART NAME: TF PUSH 外焊	
	CHECKED BY: 马跃	DATE : 2009-10-11	PART NO. 	
APPROVED BY: 邱国夷	DATE : 2009-10-11	MOLD NO. 		
UNIT: mm [inch]	SCALE: 1:1 SIZE: A4	DRAW NO: 		
		SHEET NO. 2 OF 3		

THE PACKING FOR SD CARD SERIES PUSH TYPE

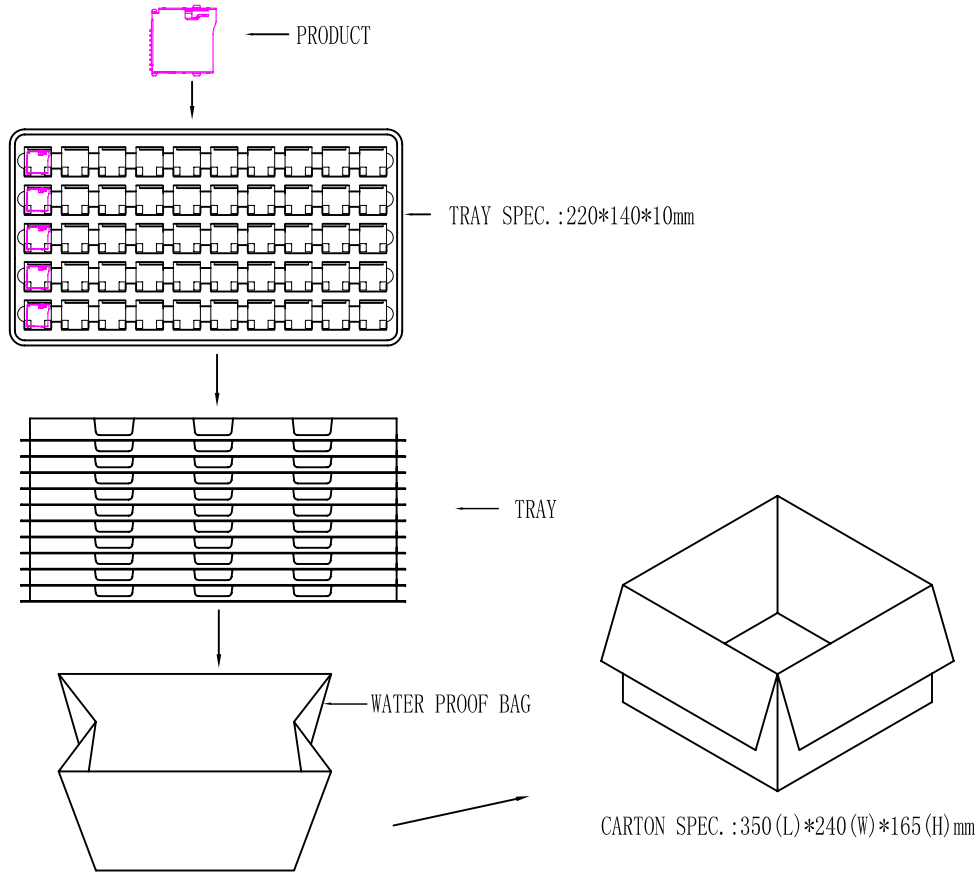

PACKING STEP

Note:

PUT PRODUCT INTO THE TRAY, AND AS SAME DIRECTION

THE DIRECTION REFERE TO DRAWING

QUANTITY OF PER TRAY:50 PCS

QUANTITY OF PER CARTON:21 TRAYS

THE TOP TRAY NOT PUT INTO PRODUCT
AS A COVER TO PROTECT PRODUCT

QUANTITY OF PER CARTON:5000 PCS

THE UNFILLING-CARTON MUST BE FILLED WITH ASSUAGEMENT

THE CARTON FULLY FILLED WITH PRODUCTS

THE MAX. ACCUMULATING QUANTITY IS 5 CARTONS

THE WEIGHT OF PER PRODUCT:1g; PER CARTON:3.15Kg

深圳市文章济美科技有限公司

TOLERANCE: X.X ±0.30 X.XX ±0.25 X.XXX ±0.15 X.' ±2' X.X' ±0.5'	DRAWED BY : 吴迪	DATE : 2009-10-11	PART NAME: TF PUSH 外焊	
	CHECKED BY: 马跃	DATE : 2009-10-11	PART NO. HYC04-TF09-200	MOLD NO. /
 UNIT: mm [inch] SCALE:1:1 SIZE: A4	APPROVED BY: 邱国夷	DATE : 2009-10-11	DRAW NO: HYC-TF09101102	SHEET NO. 3 OF 3