

REV.	ECN NO.	DESCRIPTION	DATE	DESIGN
01	----	INITIAL RELEASED	2017.11.28	Hank Pei
A	----	MODIFY THE TYPE-C PIN ASSIGNMENTS	2018.12.24	Hank Pei

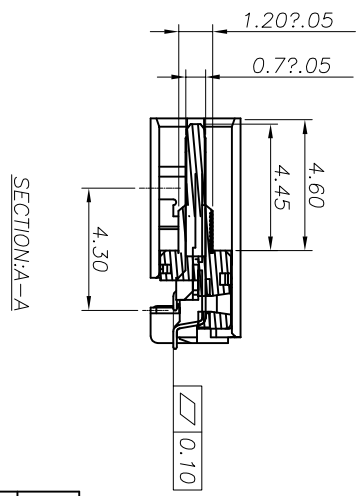
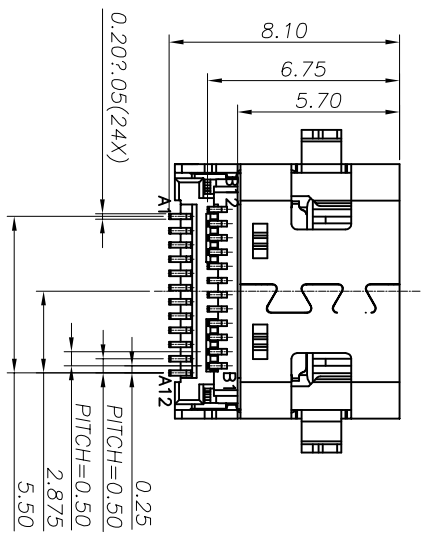
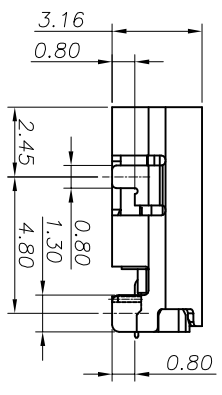
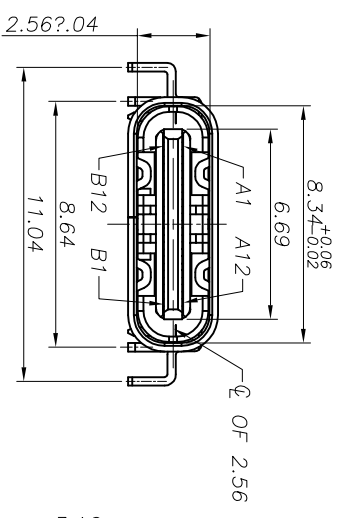
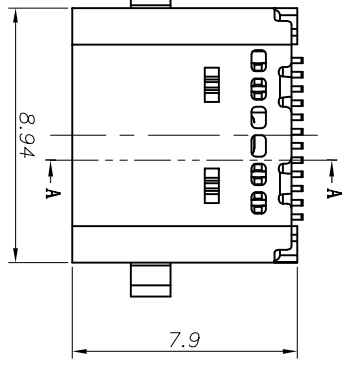
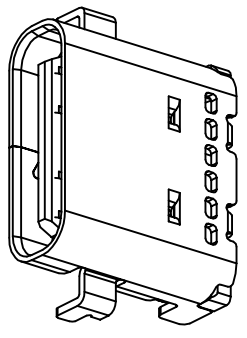

- NOTE:
 1. MATERIAL SPECIFICATION:
 1. HOUSING: HIGH TEMPERATURE RESISTANT PLASTIC, UL94 V-0.
 2. CONTACTS: COPPER ALLOY
 3. MID PLATE: STAINLESS STEEL
 4. FRONT SHELL: STAINLESS STEEL
 5. EMI PLATE: STAINLESS STEEL
 2. PLATING SPECIFICATION:
 2-1. CONTACTS:
 NI 50u" MIN. UNDER PLATED OVER ALL.
 AU PLATED ON THE FUNCTIONAL AREA OF CONTACT.
 (GOLD PLATING THICKNESS FOLLOW THE P/N)
 PLATING SPECIFICATIONS OF THE SOLDER AREA FOLLOW THE P/N
 2-2. FRONT SHELL:
 NI 30u" MIN. UNDER PLATED OVER ALL.
 2-3. MID PLATE & EMI PLATE:
 CLEAR ONLY
 3. MECHANICAL PERFORMANCE,
 3-1. INSERTION FORCE: 0.5~2.0kgf.
 3-2. REMOVAL FORCE: 0.8kgf~2.0kgf.
 3-3. DURABILITY: 10000 CYCLES.
 4. ELECTRICAL PERFORMANCE,
 4-1. CURRENT RATING: 5.0A
 VOLTAGE RATING: 5.0V
 4-2. LCR:
 VBUS & GND PINS AND OTHER PINS: 40mΩ/PIN MAX.
 SHIELD: 50mΩ/MAX.
 LCR MAX. CHANGE OF ALL PINS: 10mΩ.
 4-3. INSULATION RESISTANCE: 100MΩ MIN
 4-4. DIELECTRIC WITHSTAND VOLTAGE: AC 100V FOR 1 MINUTE.
 5. ENVIRONMENTAL PERFORMANCE:
 OPERATING TEMPERATURE: -25#~+85#.
 6. I/R REFLOW:
 THE PEAK TEMPERATURE ON THE BOARD SHALL
 BE MAINTAINED FOR 10 SECONDS AT 260°C.

TOLERANCE	NAME (INTENDED USE) CUSTOMER DRAWING	TITLE:	SCALE	SHEET	REV.
X.X ±0.30 X.X' ±10'	PART NO.	深圳市文章济美科技有限公司	SCALE	SHEET	REV.
.XX ±0.20 .X' ±8'	PART_NO.	DRAW_NAME_1	SCALE	SHEET	REV.
.XXX ±0.10 .XX' ±5'	DESIGN: DRAW	DRAW_NAME_2	SCALE	SHEET	REV.
UNITS mm		DRAWG NO.	SCALE	SHEET	REV.
MATERIALA	CHED:	DRAW_NO.	SCALE	SHEET	REV.
FINISH	APPD:	DRAW_NO.	SCALE	SHEET	REV.

REV.	ECN NO.	DESCRIPTION	DATE	DESIGN
01	----	INITIAL RELEASED	2017.11.28	Hank Pei
A	----	MODIFY THE TYPE-C PIN ASSIGNMENTS	2018.12.24	Hank Pei

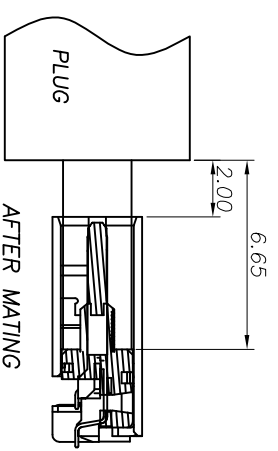

USB TYPE-C PIN ASSIGNMENTS

PIN NUMBER	SIGNAL NAME	PIN NUMBER	SIGNAL NAME
A1	GND	B12	GND
A2	SSTXp1	B11	SSRXp1
A3	SSTXn1	B10	SSRXn1
A4	VBUS	B9	VBUS
A5	CC1	B8	SBU2
A6	Dp1	B7	Dn2
A7	Dn1	B6	Dp2
A8	SBU1	B5	CC2
A9	VBUS	B4	VBUS
A10	SSRXn2	B3	SSTXn2
A11	SSRXp2	B2	SSTXp2
A12	GND	B1	GND

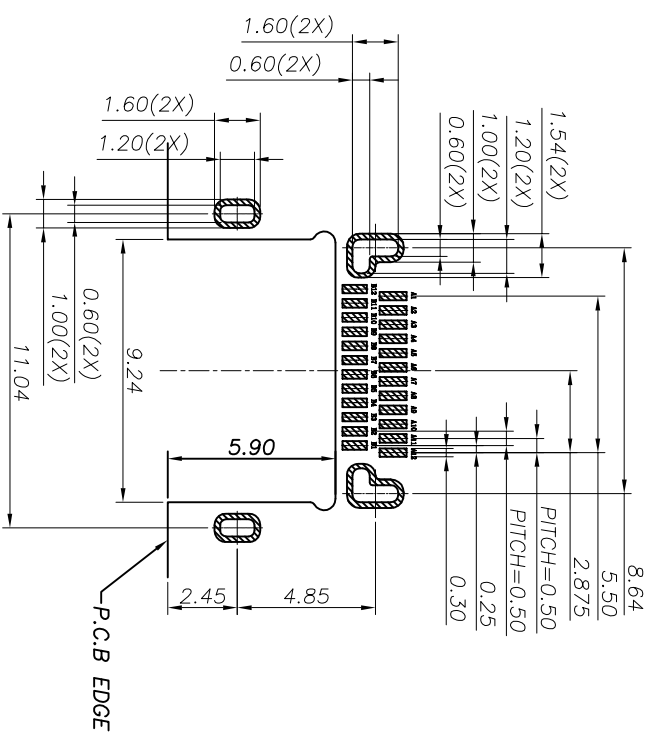

RECOMMENDED PCB LAYOUT(TOP VIEW)
THICKNESS 0.60MM;DEFAULT TOLERANCE:±0.05

ORDER INFORMATION

P/N: 5001-ACF008-1AXHXXXX-0HR
CONTACT FUNCTIONAL AREA PLATED
03: Au 3u"
15: Au 15u"
30: Au 30u"
CONTACT SOLDER AREA PLATED
1: Au 1u"

SHELL PLATING
1: Ni
HOUSING COLOR
1: BLACK
2: WHITE
5: NATURE

TOLERANCE	NAME(INTENDED USE) CUSTOMER DRAWING	TITLE:	SCALE	SHEET	REV.
X.X ±0.30 X.X' ±10"	PART NO.	深圳市文章济美科技有限公司	SCALE	SHEET	REV.
.XX ±0.20 .X' ± 8"	PART_NO.	DRAW_NAME_1	SCALE	SHEET	REV.
.XXX ±0.10 .XX' ± 5"	DESIGN: DRAW	DRAW_NAME_2	SCALE	SHEET	REV.
UNITS mm	CHEG:	DRAWG NO.	SCALE	SHEET	REV.
MATERILA	APPD:	DRAW_NO.	SCALE	SHEET	REV.
FINISH			SCALE	SHEET	REV.