

REV. ECN NO.	DESCRIPTION	DATE	DESIGN
A ECN NO.	INITIAL RELEASED	2018.07.07	Hank Pei

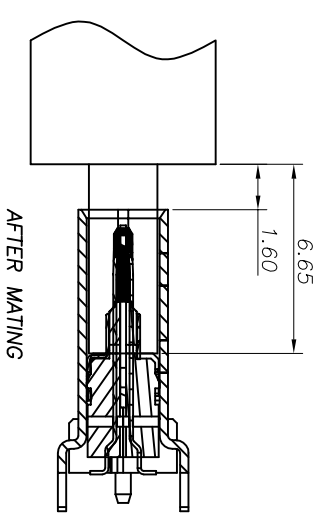

USB TYPE-C PIN ASSIGNMENTS

PIN NUMBER	SIGNAL NAME	PIN NUMBER	SIGNAL NAME
A1	GND	B12	GND
A2	SSTXp1	B11	SSRXp1
A3	SSTXn1	B10	SSRXn1
A4	Vbus	B9	Vbus
A5	CC1	B8	SBU2
A6	Dp1	B7	Dn2
A7	Dn1	B6	Dp2
A8	SBU1	B5	CC2
A9	Vbus	B4	Vbus
A10	SSRXn2	B3	SSTXn2
A11	SSRXp2	B2	SSTXp2
A12	GND	B1	GND

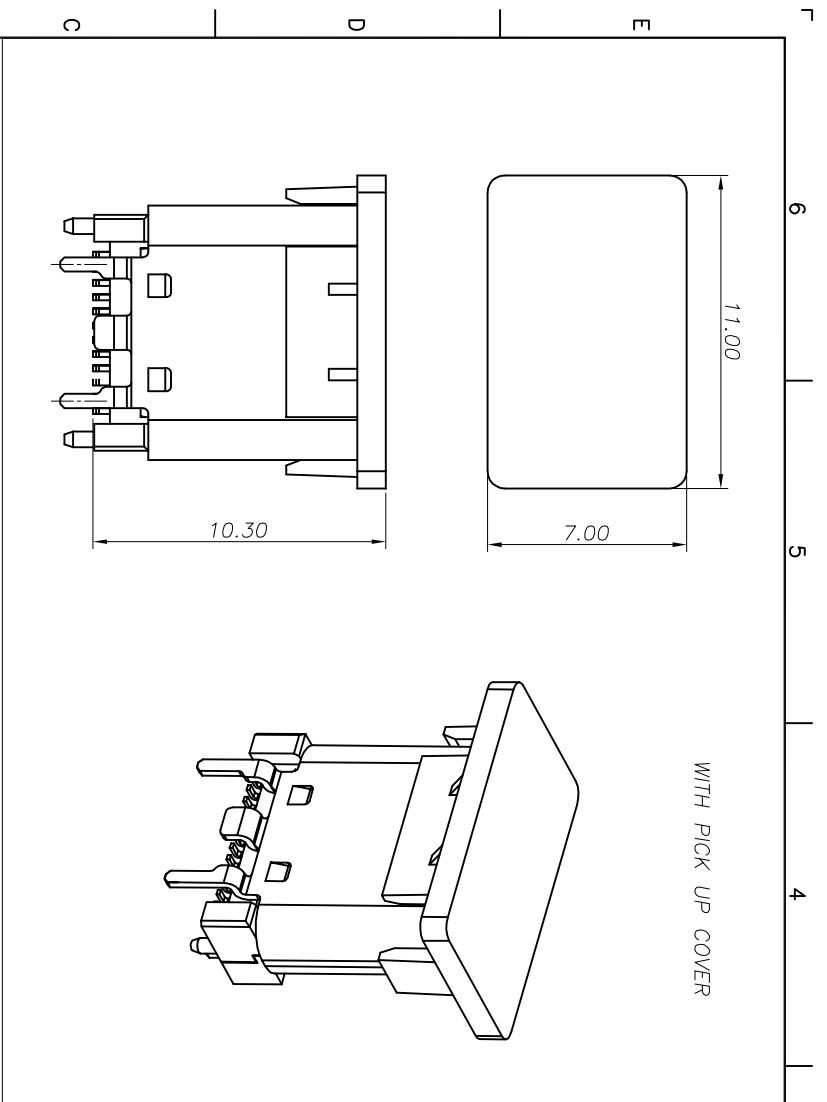
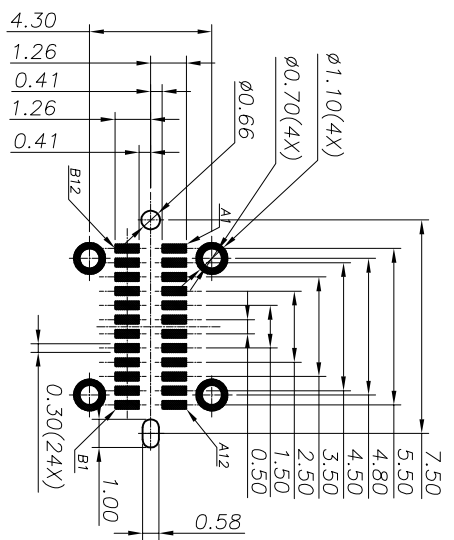

RECOMMENDED PCB LAYOUT(TOP VIEW)
THICKNESS: 1.52.10MM;DEFAULT TOLERANCE:±0.05

TOLERANCE	NAME(INTENDED USE) CUSTOMER DRAWING	深圳市文章济美科技有限公司
X.X ±0.30 X.* ±10'	PART NO.	TITLE: USB CF VERTICAL(L=9.2) TAIL LENGTH=1.25MM
.XX ±0.20 .X' ± 8'	DESIGN: HANK PEI	SCALE SHEET REV.
.XXX ±0.10 .XX' ± 5'	CHED:	5001-GAP-0141-067
UNITS mm	APPD:	1:1 2/3 A
MATERIALA		
FINISH		